

Amplifier Alphabet Soup: Part I, Basics of Power Amplifier Classes A, AB, B and C

Bill Slade

Orban Microwave Products

1. Introduction

Modern RF and microwave engineers have many more types of amplifiers at their disposal to suit specific system needs than their predecessors ever dreamed of. Some are optimized for linearity (for use in high-fidelity signal amplification) others for efficiency (where faithful reproduction is not so important; e.g. for constant carrier level signals). Still other types compromise between the two. Classes of amplifiers can more or less be lumped into two groups: the classical controlled conduction angle amplifiers and the so-called “switching” amplifiers. The first group consists of the high-fidelity Class-A and AB operating modes, the class-B and the reduced conduction-angle Class-C amplifier. The switchers include Class-D, E, F and inverse F.

Class A, AB, B and C are defined by the length of their conduction state over some portion of the waveform, such that the transistor state lies somewhere between “fully on” and “fully off”. The waveforms of the current through the transistor collector and the voltage across the collector-emitter (or drain-source) overlap significantly, causing a significant fraction of the DC input power to be converted to heat instead of useful RF power. This is because the transistor conduction state changes in step with the input waveform without any regard for the voltage or current state of the output circuit. Namely, the transistor “switches at any old time” and suffers heat dissipation as a result. Despite this, these amplifier modes are time-tested, reliably applied topologies that are straight-forward to design and are found in all types of commercial communications equipment.

The class D, E, F and inverse F switching amplifiers limit dissipation by virtue of carefully selecting the times when the transistor switches. The output network is designed such that the transistor switching transition takes place when the collector current or voltage is near zero, hence reducing the overlap between the collector voltage and current waveforms. By means of “zero-voltage” or “zero current” switching, efficiency can be improved over classical conduction-angle defined amplifier classes (A, B, AB and C) when using real-life transistor switches. Briefly said, unlike the class A, B, AB and C modes, most of the switching amplifiers (with the exception of class D) rely on selecting “special” times for changing the conduction state of the transistor.

This part of the article will focus on a qualitative review of the Class A, B, AB and C amplifier modes as well as giving some explanation on where inefficiencies appear in each. Some of the advantages and disadvantages of each topology will be presented and the trade-offs will be briefly elaborated in an intuitive manner. The active devices will be assumed to be ideal (i.e. no or only

resistive parasitics, no switching delays, etc.) to simplify the exposition. Naturally, the analysis and design of real-world amplifiers must consider the effects of parasitics. However, for clarity of exposition, effects of device parasitics are ignored.

Part II (to appear later) will cover the switching amplifier modes of operation.

2. The Classical Power Amplifier Topologies

2.1 Class-A

The Class-A amplifier is defined by a transistor that conducts current over the full 360 degrees of a cycle. Consider the simple schematic diagram in Figure 1.

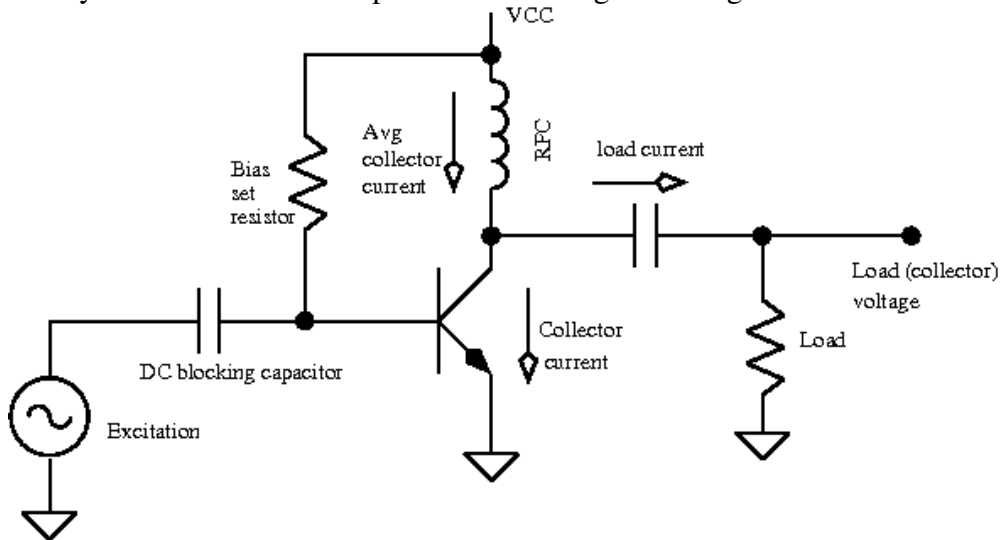

Figure 1: Generic amplifier schematic. Inductive choke used in collector circuit.

The bias resistor sets the quiescent current (collector current when there is no input signal/excitation). When there is no signal present, a constant DC current flows through the RFC inductor and there is no AC power sent to the load resistor. If the AC excitation is turned on, the collector current rises and falls in step with the input excitation. AC power is now dissipated in the load. When the amplifier is operating at peak efficiency, the current through the collector swings from zero to twice the quiescent (bias) current. If the quiescent current is defined as 0.5, the maximum current will be 1. The dotted curve in Figure 2 illustrates this behavior. The collector-emitter voltage, on the other hand, will depend on the value of the load resistor. The solid curve in Figure 2 swings between 0 and 1 because we have assumed a load resistance of 1 ohm in the simulation.

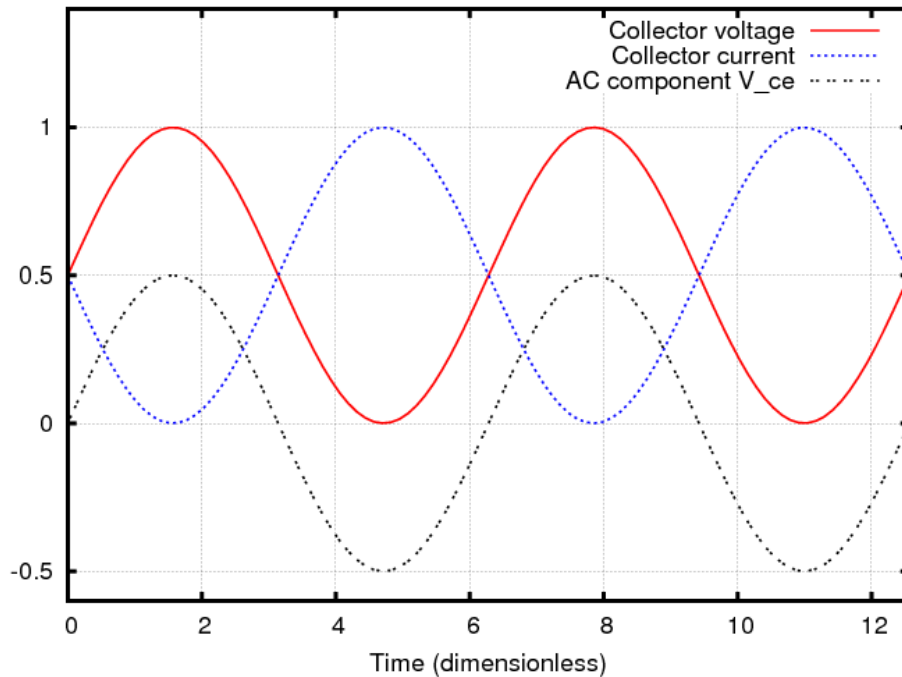

Figure 2: Currents and voltages on the output of the Class-A amplifier.

It is interesting to note that the use of an inductive choke for the DC supply as shown in Figure 1 allows a theoretical maximum efficiency of 50%. If we look at the plot of instantaneous collector dissipation and load resistor dissipation in Figure 3, we see that the average power dissipated in the load and in the transistor collector are equal, hence the figure of 50%. As the transistor collector current decreases on the falling side of the wave, the DC source “pumps” power into the load circuit (capacitor and resistor). As the transistor collector current increases, dissipation increases in the transistor and instantaneous power into the load decreases. The DC current from the supply remains practically constant. This is because the RFC inductor acts to smooth the current waveform, i.e. it is for all practical purposes an open circuit to the rapidly varying collector wave but it allows the DC to pass unhindered.

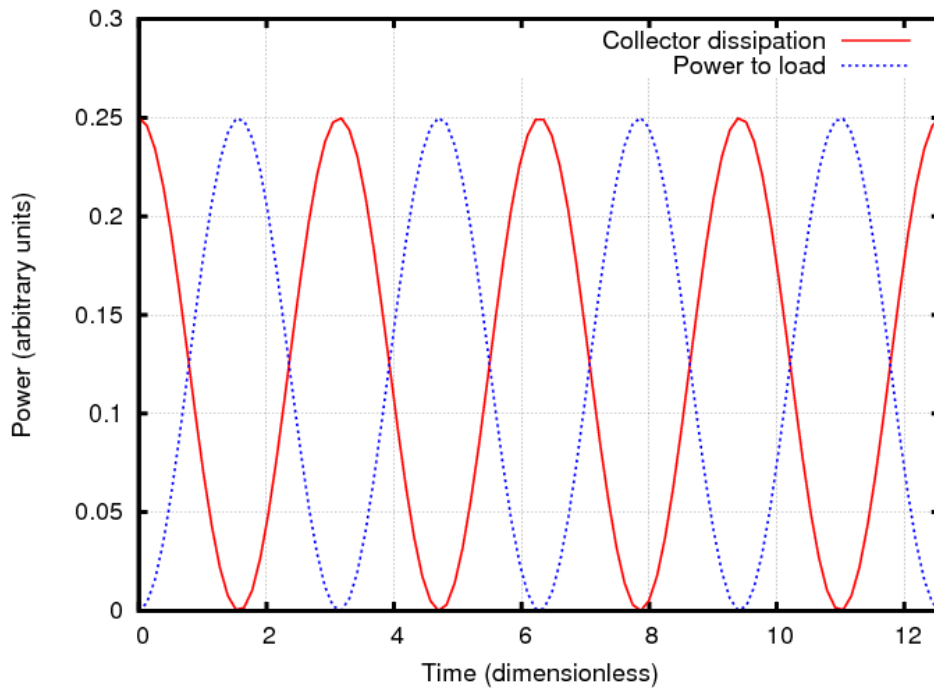

Figure 3: Plot of instantaneous power dissipation in the transistor collector and the load resistor.

This type of amplifier is seldom used in high power applications. Some “audiophile” high-fidelity audio power amplifiers may use it, since it is considered the most “linear” of the amplifier topologies. Its use in high power amplifiers would pose challenges to the designer in thermal management and power supply design. For low-power applications, the Class-A amplifier reigns supreme. Almost all RF low noise and low power gain blocks are based on Class-A amplifiers because they are simple, flexible, easily matched and preserve signal fidelity to a high extent.

Pros:

- Simplicity
- Easy matching to standard impedances
- Linearity
- Wideband
- Low noise
- High gain

Cons:

- Limited efficiency
- Low power

2.2 Class-B and AB

The single-ended Class-B amplifier has the same schematic as in Figure 1. However, the transistor is biased such that collector quiescent current is small or nearly zero. The transistor

conducts only approximately for $\frac{1}{2}$ cycle. When the base drive signal voltage falls below a certain level, the transistor collector current vanishes and the transistor is “off”. To achieve the Class-AB variant mode of operation, a small bias is applied to the base such that the transistor actually passes a small quiescent current, i.e. the conduction angle for the transistor is slightly greater than 180 degrees. This will generally reduce the efficiency somewhat from the theoretical class-B level, but amplifier fidelity is improved significantly over pure class-B operation (see Section 2.3 below).

The relationship between collector voltages and currents during operation is seen in Figure 4.

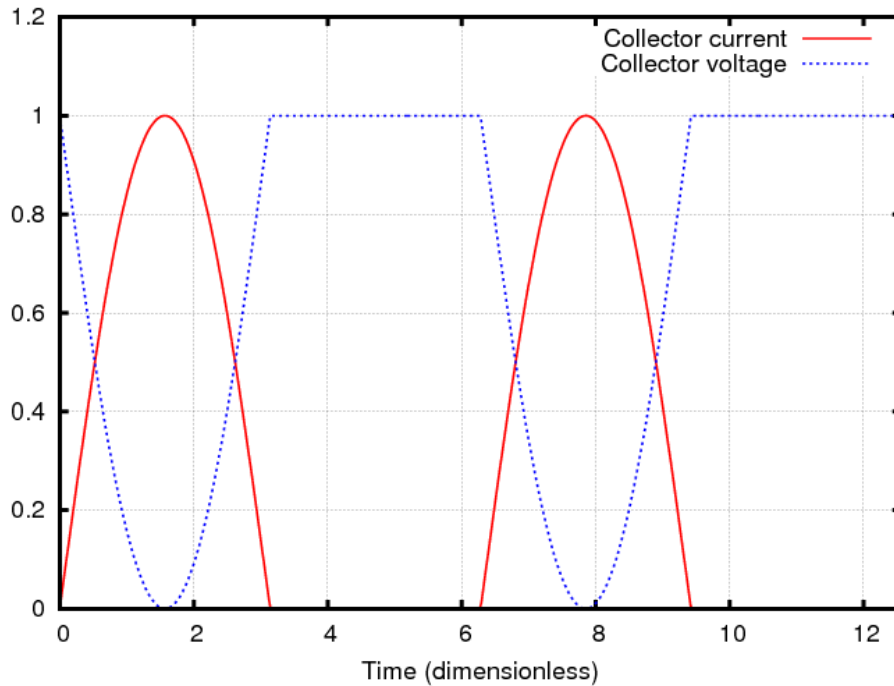

Figure 4: Collector current and collector-emitter voltage for the single-ended Class-B amplifier.

As the transistor turns on, the collector current rises, pulling the collector voltage down. The analysis is a little more involved than that of the Class-A amplifier. However, it is fairly easy to show that the power drawn from the DC supply is just the average collector current (in this case, the average of the half-sine wave over a full period, or 0.318). The power lost in the transistor is the average value of the product of the collector current and the collector-emitter voltage (the current-voltage overlap, in this example, $P_{\text{loss}} = 0.0684$). We have assumed that the voltage furnished by the DC supply is assumed to be normalized to 1 in this example. This means the total power furnished by the DC power supply is $P_{\text{supply}} = 0.318$. This puts the conversion efficiency $P_{\text{load}} / P_{\text{supply}}$ at 78.5%: the classical result. We see that by forcing the transistor to be “off” for a particular portion of the cycle, we can increase the amplifier efficiency significantly over the Class-A 50%.

In the single-ended amplifier, the output is rich in harmonics. This situation can be greatly improved by arranging two class B blocks in an “antiparallel” or so-called “push-pull” configuration (Figure 5). This is the most important and widely used amplifier topology found in high power applications.

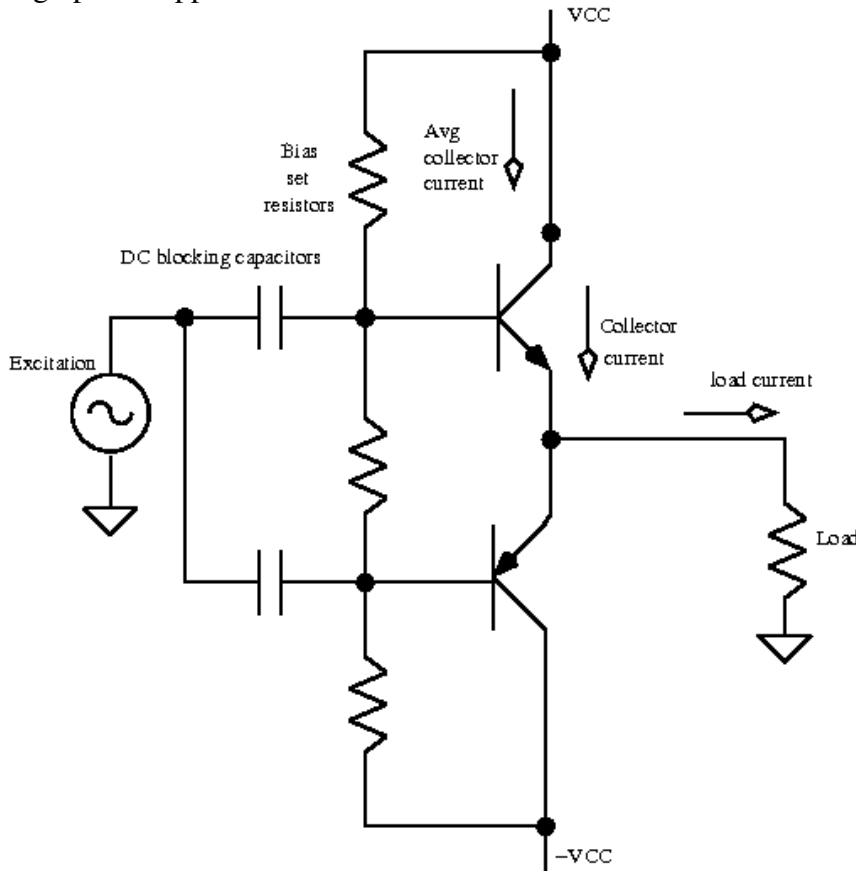

Figure 5: The “complementary” class B push-pull configuration. Note the need for a dual + / – DC supply. By a suitable choice of bias resistors, Class-AB operation is also realizable with this circuit.

In Figure 5, each transistor in the amplifier is on for ½ a cycle, just like the single-ended amplifier. However, this configuration has some notable benefits. The load resistor now experiences a swing from $-V_{cc}$ to V_{cc} . As in the single-ended example, this still yields a maximum theoretical DC to AC efficiency of 78.5%. However, now the even harmonic distortion cancels out (ideally) in the push-pull configuration. Of course, practical amplifiers will have lower efficiencies as a result of parasitic losses and device mismatches can cause some even-harmonic generation.

Note that the push-pull configuration can take a number of topological forms: some using transformer coupling or power combining on the collectors (see Figure 6) as well as half- and full-bridge designs used in power supplies, power converters, audio and high-frequency amplifiers. The push-pull configuration is also useful in switching amplifier configurations and

is used widely. Practical implementations will always have some form of harmonic filtering on the output as well.

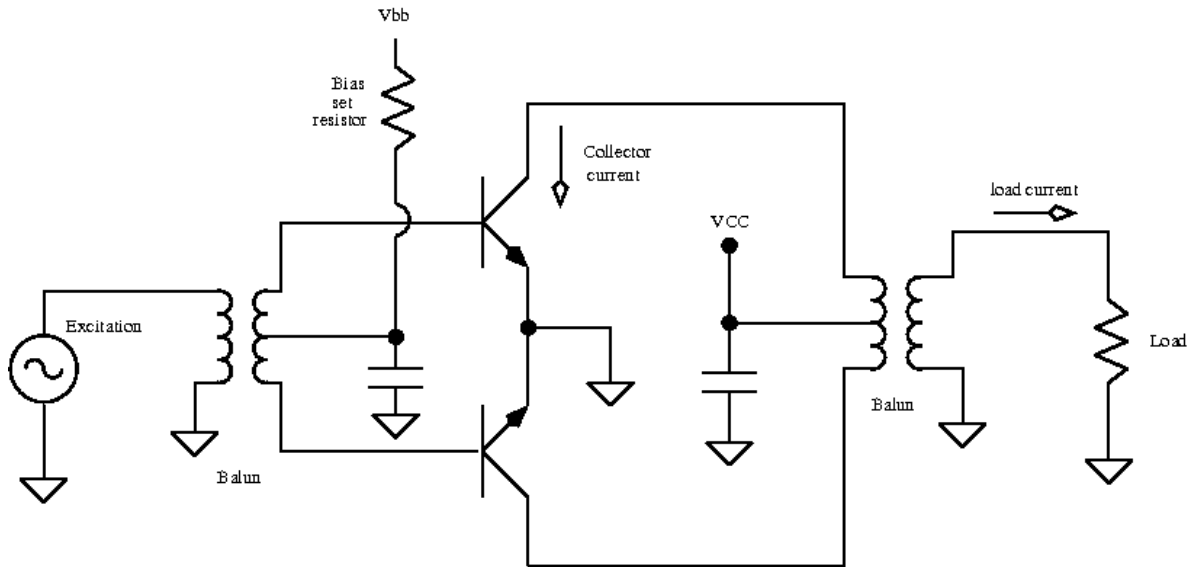

Figure 6: Another form of push-pull amplifier commonly found in RF systems. This transformer-coupled form has the benefit of requiring only a single DC supply (V_{bb} can be tied to V_{CC}).

Pros:

- Good gain
- High power
- Good theoretical efficiency
- (Mostly) Linear when operated in Class-AB
- Wideband
- Balanced operation possible
- Even harmonic cancellation

Cons:

- Complexity
- Bias control
- Can exhibit significant amplitude and phase distortion at high drive levels
- Loss in combiners/transformers

2.3 Extra note on Class-B

Practical implementations of Class-B amplifiers sometimes experience a slightly reduced angle of conduction over the what we have assumed as “perfect” Class-B operation. This occurs when the transistors are operated at a zero (or reduced) voltage base or gate bias. This causes “crossover” distortion where both transistors in the push-pull configuration are briefly in the “off” state. This

“dead-zone” is illustrated by the flat parts of the current curve near the zero-crossing points in Figure 7.

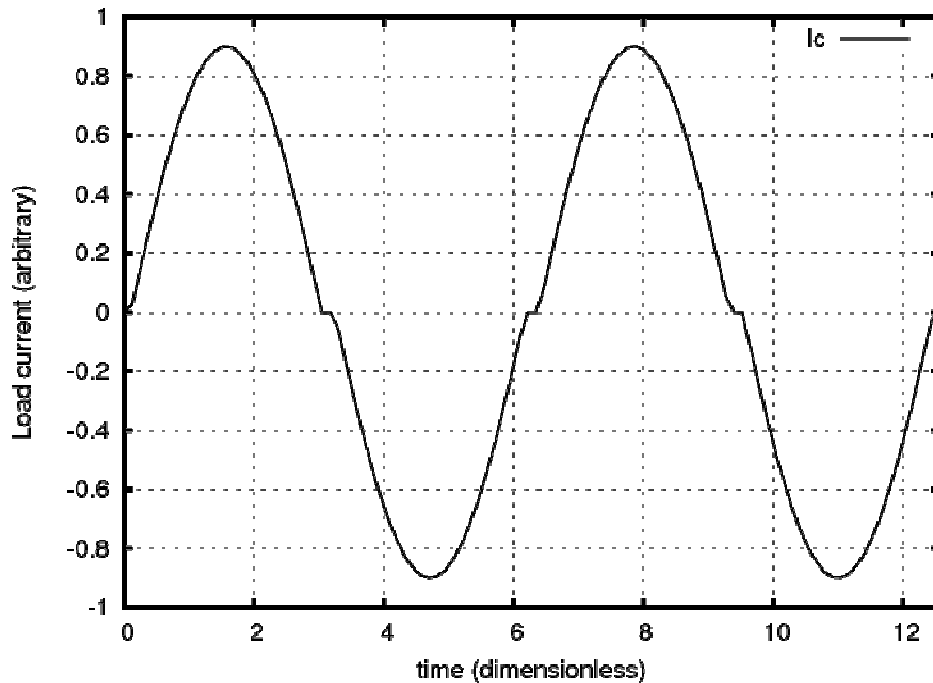

Figure 7: Class-B push-pull load current showing “crossover distortion” near zero-crossing points. In Class-B operation, the collector efficiency of practical implementations can be slightly better than the Class-AB case, but at the expense of some non-linearity and a slight reduction in gain.

2.4 Class-C

The amplification of constant-carrier level angle modulated signals reduce the need for high-fidelity signal reproduction. Whenever amplitude fidelity is not a major concern, but DC to RF conversion efficiency is a dominant design goal, operating the power transistor in a reduced conduction angle mode (less than 180 degrees) can increase efficiency over the that achievable with Class A and B modes. Class-C is the designation used when the active device is partially “on” for less than one-half of a wave cycle.

For a single ended Class-C amplifier operating over a 120 degree conduction angle (see Figure 8), the collector efficiency is calculated to be roughly 80%. Smaller conduction angles yield progressively higher collector efficiencies, but drive signal requirements tend to increase. As a result of this, Class-C amplifiers generally have lower gain than a corresponding Class-A or AB amplifier and require strong driving signals for proper operation. In fact, if we drive the amplifier hard such that the top peak “clips”, collector efficiency can be improved further.

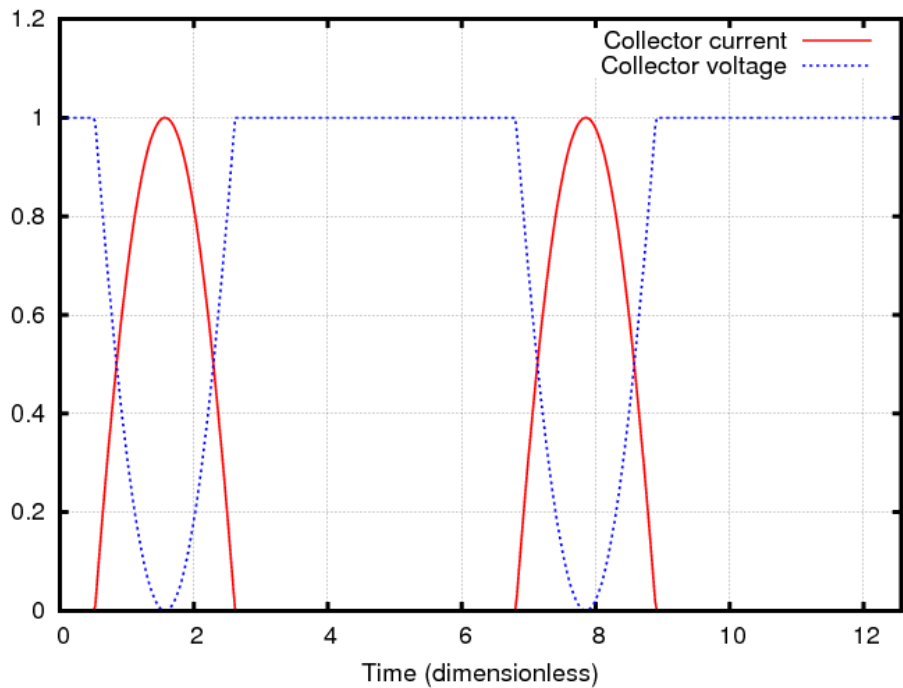

Figure 8: Reduced-conduction angle waveforms. A 120 degree conduction angle is shown.

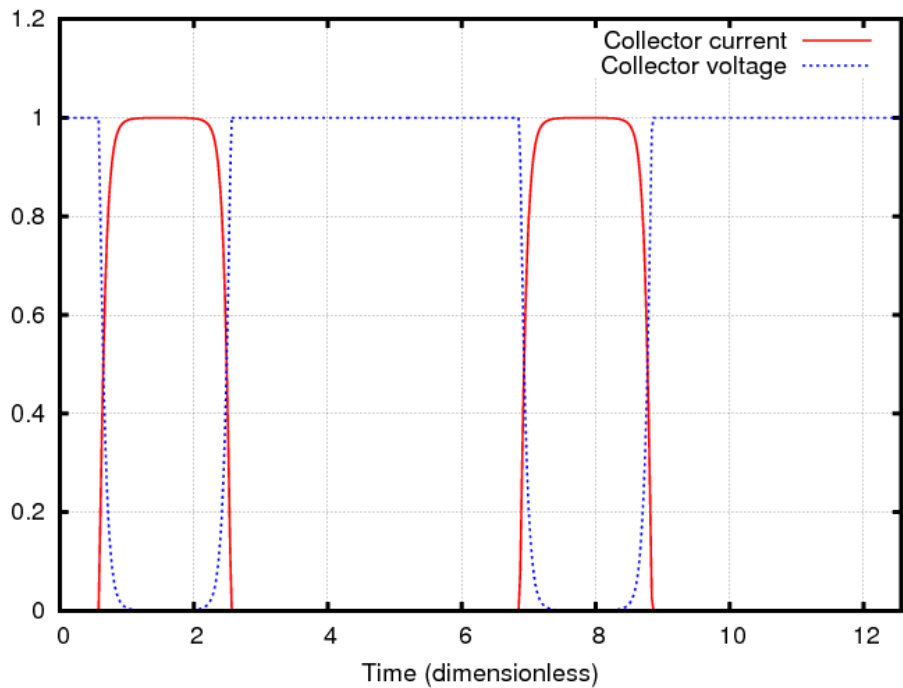

Figure 9: Class-C with clipping on the peaks.

In Figure 9, the peaks are squared off, simulating the effect of high driving signal level. As a result, the on-off transitions are steeper yielding better efficiency than in the first “truncated sine

wave” case. The computed theoretical efficiency for the clipped case is 96% . As the “switching” transitions become more square, the collector efficiency approaches 100%. The amplifier becomes a Class-D switching amplifier (to be discussed more completely in Part II). The harmonic content of the output of a Class-C amplifier is high, so some form of harmonic filtering is essential to avoid spurious harmonic signal output.

Pros:

- Simple topology
- Highly efficient
- Suitable for constant-carrier high power amplifiers

Cons:

- Lower gain than Class-A or AB.
- Strong drive signal needed
- Abundant harmonic generation
- Band-limited because usually resonant network needed on output.

Recently, the Class-C amplifier has fallen out of favor somewhat since it was more commonly used in high-power vacuum-tube amplifiers (where it is still used today, particularly in very high power FM broadcast transmitters and industrial electromagnetic heating units). The reason is that some solid-state devices can suffer damage at the high input drive levels needed for true Class-C operation. GaAsFETs are particularly susceptible to failure when drive levels are high.

3. Summary

Briefly speaking, amplifiers fall into either classes of limited-angle conduction, classical modes (Class A, AB, B and C) or on-off “switchers” where attempts are made to limit losses in the switching device (Class D, E, F, Inverse F). There is a good deal of complicated mathematical analysis that goes into the design and description of these power amplifiers. We have made no attempt to be mathematically rigorous in this article. Instead, the purpose has been to clarify the definitions as well as to give a qualitative “feel” for how these different amplifiers function. Of course, to construct amplifiers that operate in the microwave bands requires a far more profound understanding of the effects of parasitics than is presented here, but the basics of operation are still qualitatively valid.

Naturally, these classical modes of operation are still alive and well. Careful attention to detail can yield good efficiencies, especially when combined with enhancements like harmonic open and short circuits. Furthermore, Class-A, B and AB amplifiers are still a good way to produce gain well into the millimeter-wave frequency range.

Table 1 summarizes the pros and cons of the various amplifier classes and Table 2 outlines some example output powers and efficiencies for practical amplifiers.

Table 1: Brief performance comparison between various amplifier classes.

Class	Type (1)	Fidelity	Power Efficiency	Ease of implementation	Power capability	Gain (2)
A	LCA	Excellent	Poor	Very Good	Low	High
B	LCA	Medium	Good	Very Good	High	Medium/High
AB	LCA	Good	Fair	Good	Medium/High	High
C	LCA	Poor	Good	Fair	High	Low

Note (1): Active device mode of operation: LCA = Limited conduction angle (non-switching) operation, Switcher = “on-off” operation only.

Note (2): This is strongly dependent on device characteristics and operating frequency. Description is intended to give an idea of drive power needs yielding useful output in typical situations. Actual performance in practical situations will vary.

Table 2: Some example output power and efficiency numbers for the various amplifier classes and technologies.

Class	Technology	Frequency	Power	Efficiency
A	GaAs	X-band (8.5GHz)	2W	15%
AB	LDMOS	S-band (2.6GHz)	320W	50%
AB	LDMOS	UHF (860MHz)	450W	45%
AB	GaN	C-band (7GHz)	50W	35%
C	Vacuum tetrode	VHF (100MHz)	1.4MW	70%

4. References

4.1 Simulation

All simulations in this article were carried out using Octave 3.0 [1] and/or NGSpice [2] models. The reader is referred to the following websites for more information on these packages.

[1] <http://www.gnu.org/software/octave/>

[2] <http://ngspice.sourceforge.net/>

4.2 General reading

The reader is who wishes a more in-depth treatment of the subject of RF and microwave power amplifiers can consult some of the works used in the preparation of this article.

[3] S. C. Cripps, RF Power Amplifiers for Wireless Communications, Artech House, 1999.